

## Current Probe

### BST CU-19



#### CONTACT

+49 89 189 41 49-11

info@bay-sensortec.com

#### FEATURES

- Small Size
- High Current Range
- High Dynamic Range
- Anodized Aluminium Housing
- Rugged Housing and Cable
- Calibration

#### APPLICATION

- Crash test
- Including Hybrid & E-vehicles
- General Current Measuring



#### DESCRIPTION

The model BST CU-19 is a sensor to detect current on a cable, based on Hall effect technique. This sensor is for instrumentation or impact testing and many other applications. Due to the 4-wire configuration it is connectable to all data acquisition systems. The very light weight and small size of the sensor which makes it easily mountable with simple open and close clamps can be used on any positions at the car for a crash test or for shock test application. This sensor is for cable diameter up to 19.0 mm.

Due to the anodized aluminium housing it can be used for crash tests. With a 6 m, very rugged, shielded and flexible 5-wire cable all common connectors are mountable. As an option, we supply the sensor with a Shunt resistor and Dallas ID in the connector. A calibration for the sensor is obligatory.

#### DIMENSIONS

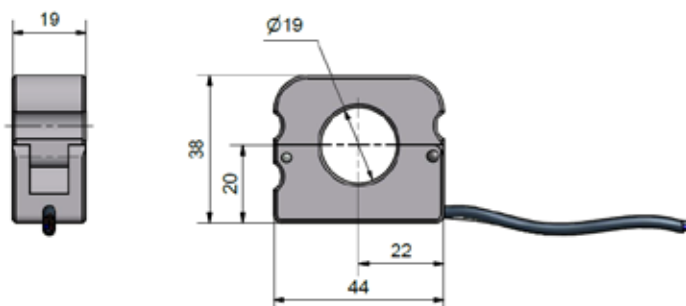

### SPECIFICATION ACCELEROMETER

All data are typical at 23 °C AND 10 VDC SUPPLY.

Range (g)	500 A max.
Sensitivity typ. (mV/g)	3,5 mV/A typ.

### ELECTRICAL PERFORMANCES

Supply voltage	5 to 10 VDC
Current Consumption	10 mA max.
Zero measurement output	+/- 25 mV typ.

### ENVIRONMENTAL PERFORMANCES

Dynamic Range	0 Hz (DC) to 10 kHz – 3 dB
Non-Linearity	+/- 1.5 % of FSO
Operation Temperature	- 20 °C to + 80 °C
Storage Temperature	- 50 °C to + 120 °C
Hole for Cable	19.0 mm
Housing Material	Aluminium, anodized
Dimensions	44.0 x 38.0 x 19.0 mm (l x w x h)
Weight Housing	80 grams without cable
Cable	integrated, 6 m shielded, AWG 30
Cable Length	6 m
Cable Material	PUR, black
Cable Weight	12 grams per meter, Ø 3.0 mm
Calibration	10 V dc and 23 °C

### CABLE CODE

red = Excitation +  
black = Excitation –

green = Signal +  
white = Signal –

### ORDER INFORMATION

BST CU-19-6Z
CU = Model name
19 = max. Cable diameter
6 = 6 m Cable
Z = no connector

### OPTIONAL

Additional Cable Length
Connector
Dallas ID
TEDS
Shunt Resistor