

PE Accelerometer

BST 98 Uniaxial



CONTACT
+49 89 189 41 49-11
info@bay-sensortec.com

FEATURES

- Cubic form
- Side Connector
- Small Size
- TEDS
- Mounting with Plastic clip
- Calibration

APPLICATION

- Modal and Structure analysis
- Train
- Motion
- Automotive
- Comfort



DESCRIPTION

The model BST 98 is a small uniaxial accelerometer based on IEPE Shear design with a very good Signal-to-Noise Ratio. The accelerometers are designed for relatively low amplitudes. The housing is mountable with a Plastic clip Type 1407. The sensor has very high rugged and flexible cable. This makes it easy to connect the sensor on data acquisition systems. It operates between 2 and 20 mA constant current. The housing is Aluminium.

DIMENSIONS

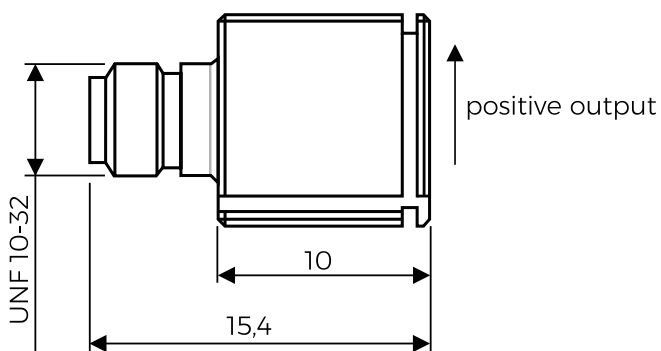

SPECIFICATION ACCELEROMETER

All data are typical at 23 °C AND 10 VDC SUPPLY.

Range (g)	55 and 550
Supply constant current	2 to 20 mA
DC Output BIAS Voltage	12 – 14.5 V at 25 °C (+/- 10 %)
Shock limit (g)	8,000

MECHANICAL DATA

Operation Temperature	- 40 °C to + 120 °C
Protection Class	IP64
Mounting	Mount with a Plastic Clip 1407 or Glue
Weight	3.0 g for 500 g range 3.8 g for 55 g range
Dimensions	10 x 15.4 x 10 mm (l x w x h)
Case material	Aluminium
Transverse Sensitivity	< 5 %
Non-Linearity FSO	2 %
Cable-Connector	UNF 10-32

INDIVIDUAL DATA

	55	550
Range (g)	55	550
(m/s ²)	490	4,900
Frequency (5 %)	0.45 – 5 k	0.6 – 8 k
(10 %)	0.3 – 7.5 k	0.4 – 10 k
(3dB Hz)	0.15 – 11 k	0.2 – 16 k
Resonance Frequency (kHz)	> 24	> 24
Sensitivity (mV/g)	100	10
(mV/m/s ²)	10.2	1.02
Phase Response (kHz +/- 5°)	1.4 – 3.3	1.8 – 3.3
Noise (µg/√Hz)		
0.1 Hz	30	300
1.0 Hz	8	80
10 Hz	3	30
100 Hz	0.8	8
Temperature Coefficient (%/K)		
(- 40 – +/- 0°C)	- 0.03	- 0.03
(+/- 0 – + 40°C)	- 0.06	+/- 0
(+ 40 – 80°C)	- 0.08	- 0.04
(+ 80 – 120°C)	- 0.11	- 0.08
Temperature Sensitivity (ms ² /K)	0.3	1.5

ORDER INFORMATION

BST 98-010
58 = Model name
010 = Sensitivity 10mV/g (Range 550 g)

OPTIONAL

Additional Cable Length
Connector
TEDS
Plastic Clip 1407